High Voltage Busbar Protection

Course No: E05-012

Credit: 5 PDH

Velimir Lackovic, Char. Eng.



Continuing Education and Development, Inc.
22 Stonewall Court
Woodcliff Lake, NJ 07677

P: (877) 322-5800
info@cedengineering.com

HIGH VOLTAGE BUSBAR PROTECTION

The protection arrangement for an electrical system should cover the whole system against all possible faults. Line protection concepts, such as overcurrent and distance arrangements, satisfy this requirement, even though short circuits in the busbar zone are cleared after certain time delay. But in the case, unit protection is used for feeders and plants, the busbars are not inherently protected. Busbars have typically been left without dedicated protection, from the following reasons:

- the busbars and switchgear are highly reliable
- it was believed that inadvertent operation of busbar protection might cause cascade tripping
- it was believed that electrical system protection or back-up protection would give adequate bus protection if necessary

It is a fact that the risk of a short circuit happening on modern metal clad equipment is insignificant, but it cannot be completely dismissed. Nevertheless, the damage resulting from one short circuit may be huge, up to the overall loss of the substation by fire. Severe damage or destruction would possibly end in widespread and prolonged supply disruption.

Eventually, electrical system relay protection typically, will not give the needed cover. Such protection may be sufficient for small distribution substations, but not for vital substations. Even if distance protection is used for all utility feeders, the busbar will be located in the second protection zone of all the distance protections, so a bus short circuit will be slowly cleared, and the resultant voltage dip may not be permissible.

In the case of outdoor switchgear, the situation is less clear since. Even though the likelihood of a short circuit is greater, the risk of widespread damage is lower. In principle, busbar protection is needed when the system protection does not protect the busbars, or when, in order to keep power system stability, high-speed short circuit current clearance is needed. Unit busbar protection meets these requirements. Also, in the case busbars sections are separated, only one section

needs to be isolated to clear a fault. Busbar protection is actually the strongest when bus sections are separated.

BUSBAR FAULTS

Most of the bus faults involve one phase and ground, but faults are caused by many causes and a great number are interphase clear of ground. In fact, a great proportion of busbar faults are caused by human error rather than the failure of switchgear components. With totally phase-segregated metal clad equipment, only ground faults are possible, and a protection configuration needs to have only ground fault sensitivity. In other situations, an ability to react to phase faults that do not involve ground is an advantage, even though the phase fault sensitivity does not need to be high.

PROTECTION REQUIREMENTS

Even though not fundamentally different from other circuit protection, the key busbar position increases the emphasis placed on the basic requirements of speed and stability. The special characteristics of busbar protection are elaborated below.

SPEED

Busbar protection is mainly concerned with:

- limitation of consequential damage
- busbar fault clearance in less time than could be accomplished by back-up line protection, with the object of keeping system stability

Some early busbar protection configurations applied a low impedance differential system that has a relatively long operation time, of up to 0.5 seconds. The foundation of most modern configurations is a differential system using either low impedance biased or high impedance unbiased relays. They are capable of tripping in a time of the order of one cycle at a very moderate multiple of fault setting. Operating time of any tripping protection relays must be added to this time, however an overall tripping time of less than two cycles can be accomplished. With high-speed circuit breakers, total fault clearance may be obtained in roughly 0.1 seconds. When a frame-ground system is applied, the operating speed is similar.

STABILITY

Bus protection stability is of critical importance. Keeping in mind the fault incidence low rate, it is evident that unless the stability of the protection is absolute, the disturbance degree to which the power system is likely to be subjected may be increased by the installation of bus protection. The chance of incorrect operation has led to hesitation in using bus protection and has also led to installation of some very complex configurations. Increased understanding of the differential system response to transient currents allows such systems to be used with trust in their fundamental stability. Notwithstanding, the overall stability of an adequately used protection configuration, dangers exist in reality for a number of reasons. These reasons include:

- interruption of the current transformer secondary circuit will create an unbalance, which might start tripping on load depending on the circuit load relative values and effective setting. Certainly, it would do so during a through fault, generating substantial fault current in the analyzed circuit
- a mechanical shock of sufficient severity may start operation, even though the likelihood of this happening with modern numerical configurations is decreased
- accidental interference with the protection relay, developing from a mistake during maintenance testing, may lead to tripping

In order to keep the high order of integrity required for busbar protection, it is an almost constant practice to make tripping depend on two separate measurements of fault quantities. Also, if the tripping of all the breakers within a zone is derived from common measuring relays, two separate elements have to be operated at each stage to complete a tripping process.

The two measurements may be completed by two similar differential systems, or one differential system may be checked by a frame-ground system, by ground fault relays energized by current transformers in the transformer neutral-ground

conductors or by voltage or overcurrent protection relays. Optionally, a frame-ground system may be checked by ground fault protection relays. If two systems of the unit or other similar type are applied, they should be energized by different current transformers in the case of high impedance unbiased differential configurations. The duplicate ring CT cores may be installed on a common primary conductor but independence must be kept throughout the secondary circuit. In the case of low impedance, biased differential configurations that cater for different ratio CTs, the arrangement can be energized from either one or two different sets of main current transformers. The criteria of double feature operation before tripping can be kept by the provision of two sets of ratio matching interposing CTs per circuit. When multi-contact tripping relays are applied, these are also duplicated, one being energized from each discriminating protection relay. The contacts of the tripping protection relay are then series-connected in pairs to give tripping outputs. Separate tripping relays, each controlling only one breaker, are typically preferred. The importance of such protection relays is then no more than that of normal circuit protection, so no duplication is needed at this stage. Not least among the benefits of using separate tripping relays is the simplification of trip circuit wiring, in comparison with taking all trip circuits related with a given bus section through a common multi-contact tripping relay.

In double busbar systems, a different protection configuration is used for each section of each busbar. Complete check system is also provided, covering all sections of both busbars. The separate zones are made to overlap the busbar section switches, so that a fault on the section switch trips both the adjacent zones. This has been avoided in the past by providing the section switch a time advantage. The section switch is operated first and the remaining breakers are delayed by 0.5 seconds. Only the zone on the section switch faulty side will remain operated and trip, the other zone resetting and retaining that section in service. This gain, applicable only to very rare section switch faults, is got at the expense of seriously delaying the bus protection for all other faults. Therefore, this pattern is not typically favored. There are numerous possible combinations, but the basic principle is that no single accidental incident of a secondary nature is able to cause an unnecessary bus section trip.

Security against maloperation is only accomplished by increasing the number of devices that are needed to function to complete an operation. This inevitably increases the statistical risk that a tripping operation due to a fault may fail. Such a failure, leaving aside the question of consequential damage, may end in power system disruption to an extent greater than would be caused by an unwanted trip. The relative failure risk of this kind may be small, but it has been worthwhile to provide a guard in this respect as well. Stability and operation security is obtained by supplying three independent channels (say X, Y and Z) whose outputs are organized in a 'two-out-of-three' voting scheme, as presented in Figure 1.

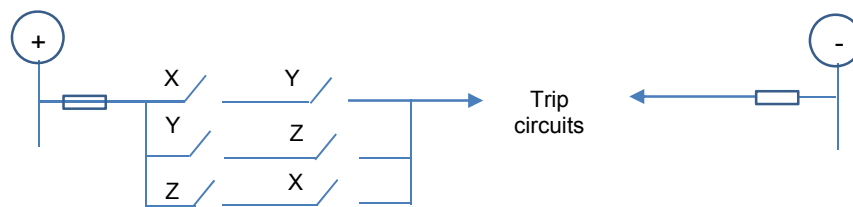

Figure 1. Two out of zone three arrangement

PROTECTION SYSTEM TYPES

A number of busbar protection arrangements have been prepared:

- system protection used to cover busbars
- frame-ground protection
- directional blocking protection
- phase comparison protection
- differential protection

Of these, system protection used to cover busbars is only appropriate for small substations. Phase comparison protection is typically seen only as a supervision check device within biased differential numerical configurations. Directional blocking protection is getting higher acceptance when implemented as IEC 61850 GOOSE-based configuration using overcurrent protection relays. Early configurations of busbar biased differential protection, such as versions of 'Translay' protection and also a configuration using harmonic restraint, were replaced by unbiased high

impedance differential protection. The relative simplicity of the latter, and more importantly the relative simplicity with which its performance can be computed, have ensured its success. However, in the 1980's the developments in semiconductor technology, coupled with a more pressing need to be able to use different ratio CTs, led to the re-introduction of biased configurations, typically using static relay arrangements, especially for the most extensive and onerous applications. Frame-ground protection systems have been in service for many years, mainly related with smaller busbar protection configurations at distribution voltages and for metal clad busbars (e.g. SF6 insulated busbars). Nevertheless, it has often been common for a unit protection configuration to be used in addition. It is used to provide two different fault detection methods.

SYSTEM PROTECTION CONFIGURATIONS

System protection that involves overcurrent or distance configurations will inherently provide protection cover to the busbars. Overcurrent protection will only be used for rather simple distribution networks, or as a back-up protection, set to provide a significant time delay. Distance protection will give cover for busbar faults with its second and possibly subsequent zones. In both situations provided busbar protection is slow and useful only for limiting the consequential damage. The only exception is the case of a mesh-connected substation, in which the current transformers are installed at the circuit breakers. Here, the busbars are included, in sections, in the main circuit protection individual zones, whether this is of unit type or not. In the special situations when the current transformers are installed on the line side of the mesh, the circuit protection will not include the busbars in the instantaneous zone and separate busbar protection, known as mesh-corner protection, is typically applied.

FRAME-GROUND PROTECTION (HOWARD PROTECTION)

Frame leakage protection has been applied in the past in many different cases. There are few variations of frame leakage configurations, providing busbar protection arrangements with different capabilities. Configurations presented in the next sections have thus been kept for historical and general reference purposes. A significant number of configurations are still in operation and frame leakage may give

an acceptable solution in particular circumstances. Nevertheless, the requirement to insulate the switchboard frame and give cable gland insulation and the availability of alternative configurations using numerical protection relays, has contributed to a decline in use of frame leakage systems.

SINGLE-BUSBAR FRAME-GROUND PROTECTION

This is exclusively ground fault system and includes measurement of the fault current flowing from the switchgear frame to ground. A current transformer is installed on the grounding conductor and is used to energize a simple instantaneous protection relay as presented in Figure 2.

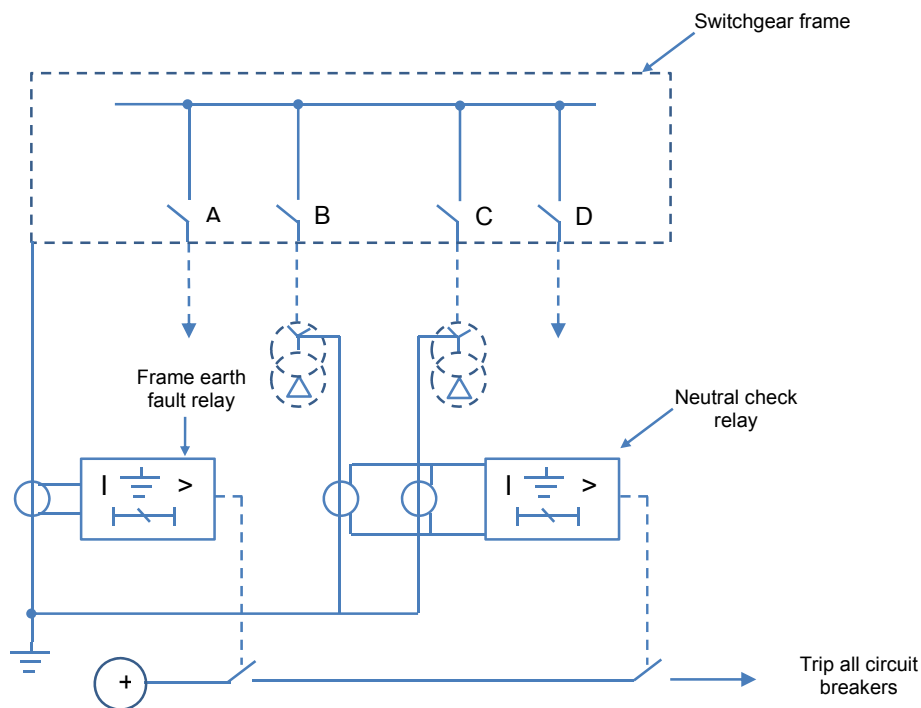

Figure 2. Single zone frame ground protection

No other ground connections of any type, including accidental connections to structural steelwork are allowed. This demands is so that:

- the main ground connection and current transformer are not shunted, thereby increasing the effective setting. An increased effective setting increases the possibility of protection relay maloperation. This risk is small in reality.

- ground current running to a fault elsewhere on the system cannot run into or out of the switchgear frame via two ground connections, as this might lead to a spurious operation

The switchgear needs to be insulated as a whole, typically by placing it on concrete. Attention has to be taken that the foundation bolts do not touch the steel reinforcement. Adequate concrete has to be cut away at each hole to allow grouting-in with no risk of touching metal work. The accomplished insulation to ground will not be high, a value of 10Ω being sufficient. When planning the grounding arrangements of a frame-leakage configuration, the application of one common electrode for both the switchgear frame and the power system neutral point is favored, because the fault path would otherwise include the two grounding electrodes in series. If either or both of these are of high resistance or have insufficient current carrying capacity, the fault current may be set to such an extent that the protection device becomes inoperative. In addition, if the electrode grounding the switchgear frame is the offender, the potential of the frame may be increased to a dangerous value. The application of a common grounding electrode of sufficient rating and low resistance makes sure sufficient current for configuration operation and limits the rise in frame potential. When the arrangement is resistance grounded, the grounding connection from the switchgear frame is made between the bottom of the grounding resistor and the grounding electrode. Figure 3 presents why a lower limit of 10Ω insulation resistance between frame and ground is needed.

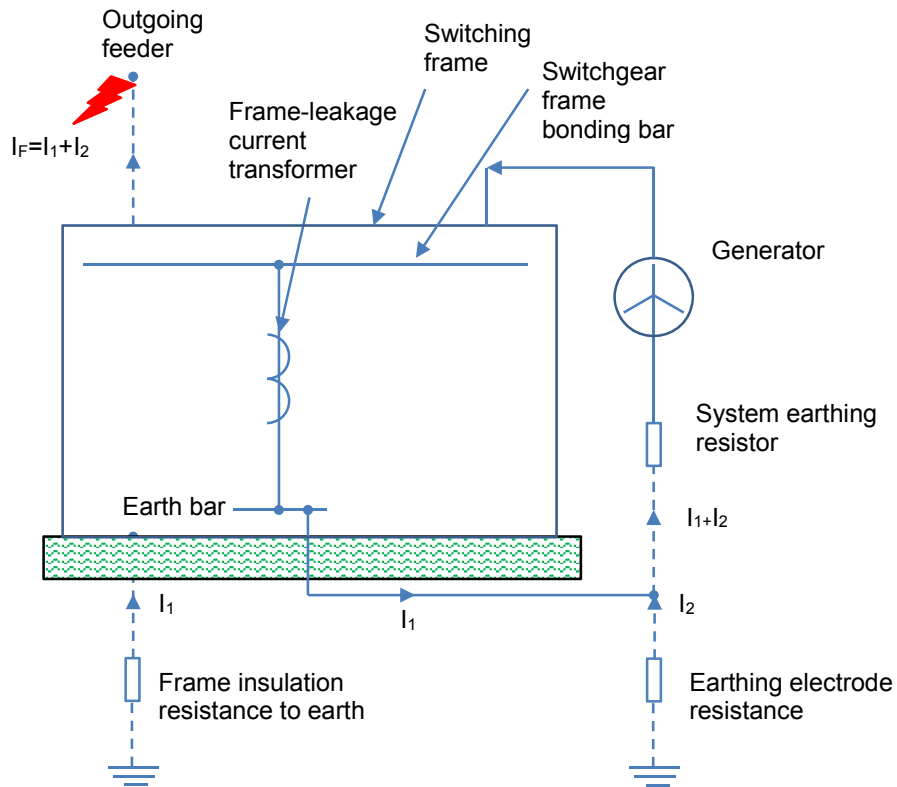

Figure 3. External fault current distribution

Under external fault conditions, the current I_F runs through the frame-leakage current transformer. If the insulation resistance is too low, adequate current may run to trip the frame-leakage protection relay, and, as the check option is unrestricted, this will also operate to complete the trip circuit. The ground resistance between the grounding electrode and true ground is rarely higher than 1Ω , so with 10Ω insulation resistance, the current I_1 is fixed to 10% of the complete ground fault current I_1 and I_2 . For this reason, the suggested minimum setting for the configuration is around 30% of the minimum ground fault current.

All cable glands have to be insulated, to stop the spurious current circulation through the frame and grounding system by any voltages induced in the cable sheath. Rather, the gland insulation should be made in two layers or stages, with an interposing layer of metal, to allow the gland insulation testing. A test level of 5kV from each side is appropriate.

FRAME-GROUND PROTECTION - SECTIONED BUSBARS

When the busbar is separated into sections, they can be protected separately. However, the frame has to also be sub-divided, the sections mutually insulated, and each section needs to have a separate ground conductor, current transformer and protection relay. In ideal situation, the section switch should be looked at as a separate zone, as presented in Figure 4. It also needs to be provided with either a separate protection relay or two secondaries on the frame-leakage current transformer, with configuration to trip both adjacent zones. The individual zone protection relays operate their respective zone and the section switch.

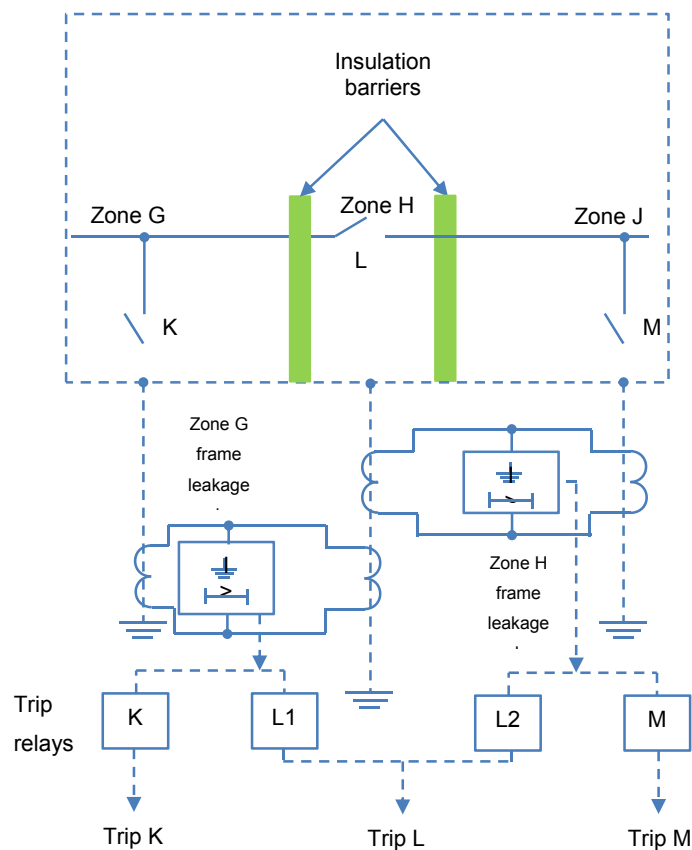

Figure 4. Three zone frame ground configuration

If it is difficult to insulate the section switch frame on one side, this switch may be included in that zone. It is then mandatory to inter-trip the other zone after roughly 0.5 seconds if a fault remains after the zone including the section switch has been tripped. This process is presented in Figure 5.

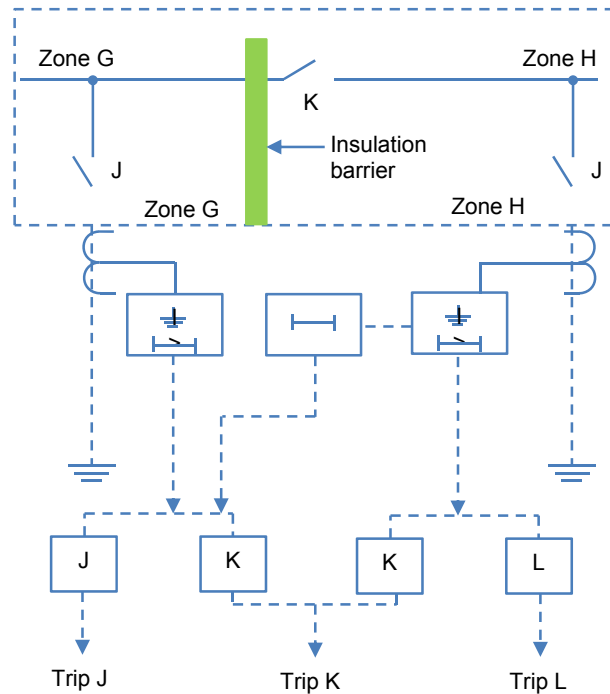

Figure 5. Frame-ground configuration: bus section breaker insulated only on one side

It is mandatory to have a least one power infeed or grounded supply source, for the above configuration to function. In the second case it is necessary that this supply source is connected to the switchboard side that does not contain the section switch. Also, it is preferred that ground source of supply is provided on both sides of the switchboard, in order to make sure that any faults that may happen between the insulating barrier and the section switch will continue to be supplied with fault current after the isolation of the first half of the switchboard. This will allow the fault to be cleared. Of the two configurations, the first is the one typically suggested, since it allows instantaneous busbar faults clearance on all switchboard sections.

FRAME-GROUND CONFIGURATION - DOUBLE BUS SUBSTATION

It is not typically feasible to separately insulate the metal enclosures of the main and auxiliary busbars. Hence, protection is typically arranged as for single bus configurations, but with the extra option that circuits connected to the auxiliary bus are tripped for all faults. This is presented in Figure 6.

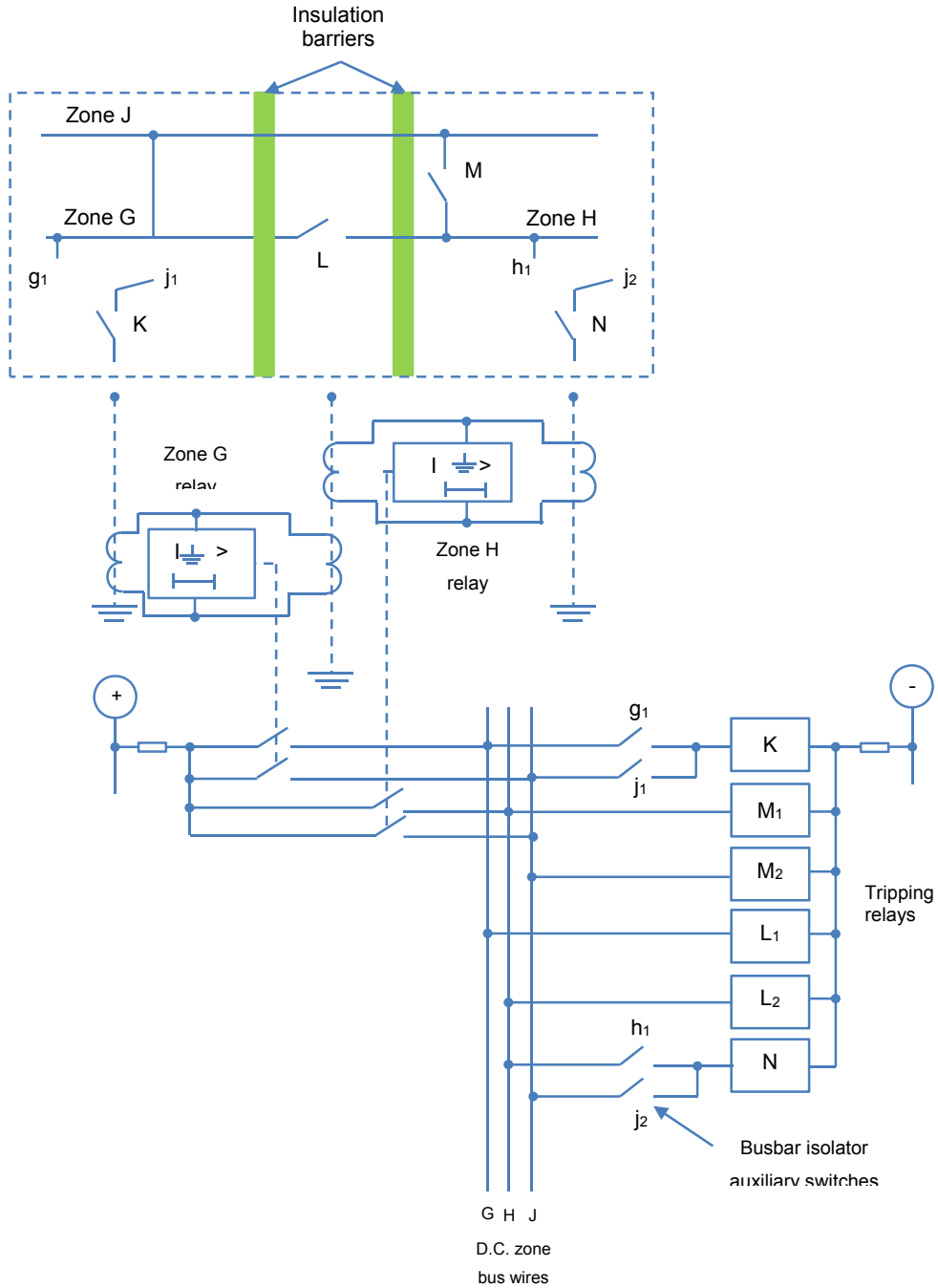

Figure 6. Frame-ground configuration for double busbar substation

FRAME-GROUND PROTECTION - CHECK SYSTEM

On the smallest devices, a check system should be given to protect against such contingencies such as operation due to mechanical shock or staff mistakes. Faults in the low voltage auxiliary wiring must also be stopped from causing tripping by

transferring current to ground through the switchgear frame. A useful verification is provided by a protection relay energized by the system neutral current, or residual current. If the neutral check cannot be accomplished, the frame-ground protection relays should have a short time delay. When a check system is applied, instantaneous protection relays can be used, with a setting of 30% of the minimum ground fault current and an operating time at five times setting of 15 milliseconds or less.

Figure 7 presents a frame-leakage configuration for a metal clad switchgear arrangement similar to that presented in Figure 4 and containing a neutral current check got from an appropriate zero sequence current sources, such as that presented in Figure 2.

The protection relays used for the discriminating and check operations are of the attracted armature type, with two open self-reset contacts. The tripping circuits are not complete unless both the discriminating and check relays function. This happens because the discriminating and check relay contacts are connected in series. The tripping relays are of the attracted armature type. It is common to supervise the acceptable operation of the protection configuration with audible and visual alarms and indications for the following:

- busbar faults
- busbar protection out of service
- busbar protection in service
- alarm supply healthy
- tripping supply healthy

To allow the protection equipment of each zone to be taken out of service independently during maintenance intervals, isolating switches - one switch per zone - are installed in the trip supply circuits and an alarm cancellation relay is installed.

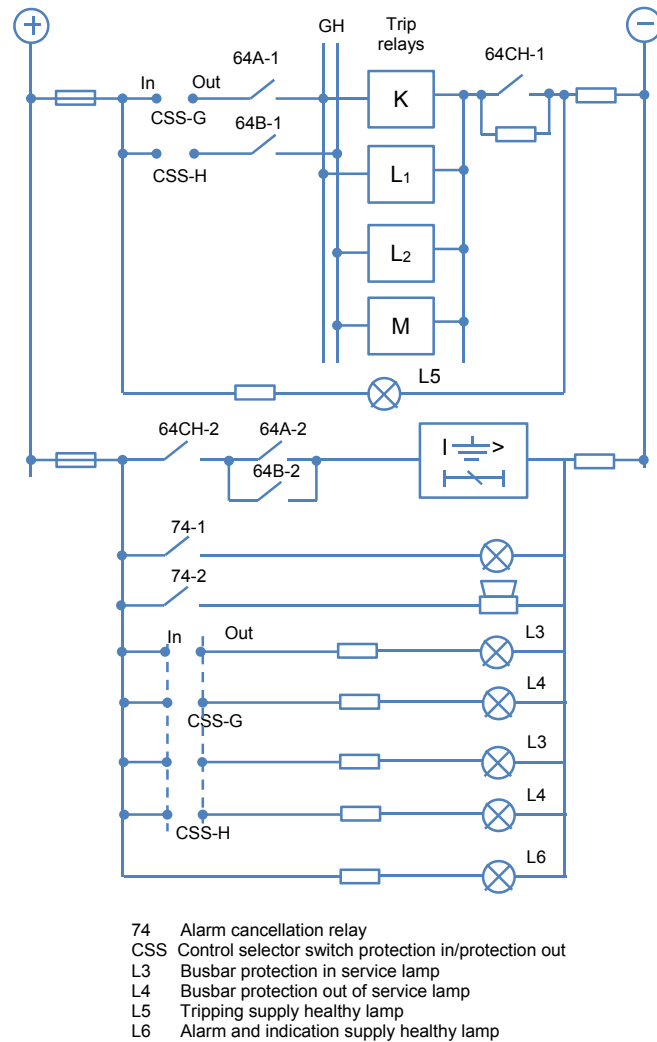

Figure 7. Common tripping and alarm circuits for a frame-leakage configuration

DIFFERENTIAL PROTECTION METHODS

The Merz-Price principle can be applied to a multi-terminal zone such as a busbar. This method is a direct application of Kirchhoff's first law. Typically, the circulating current configuration is applied, in which the current transformers and interconnections form an analogue of the busbar and circuit connections. A protection relay connected across the CT bus wires makes a fault path in the primary system in the analogue. Therefore, it is not energized until a fault happens on the busbar. Then it receives an input that represents the fault current.

The configuration may consist of a single protection relay connected to the bus wires connecting all the current transformers in parallel, one set per circuit, related with a particular zone, as presented in Figure 8(a). This will give ground fault protection for the busbar. This configuration has often been thought to be appropriate.

If the current transformers are installed as a balanced group for each phase together with a three-element protection relay, as presented in Figure 8(b), extra protection for phase faults can be achieved.

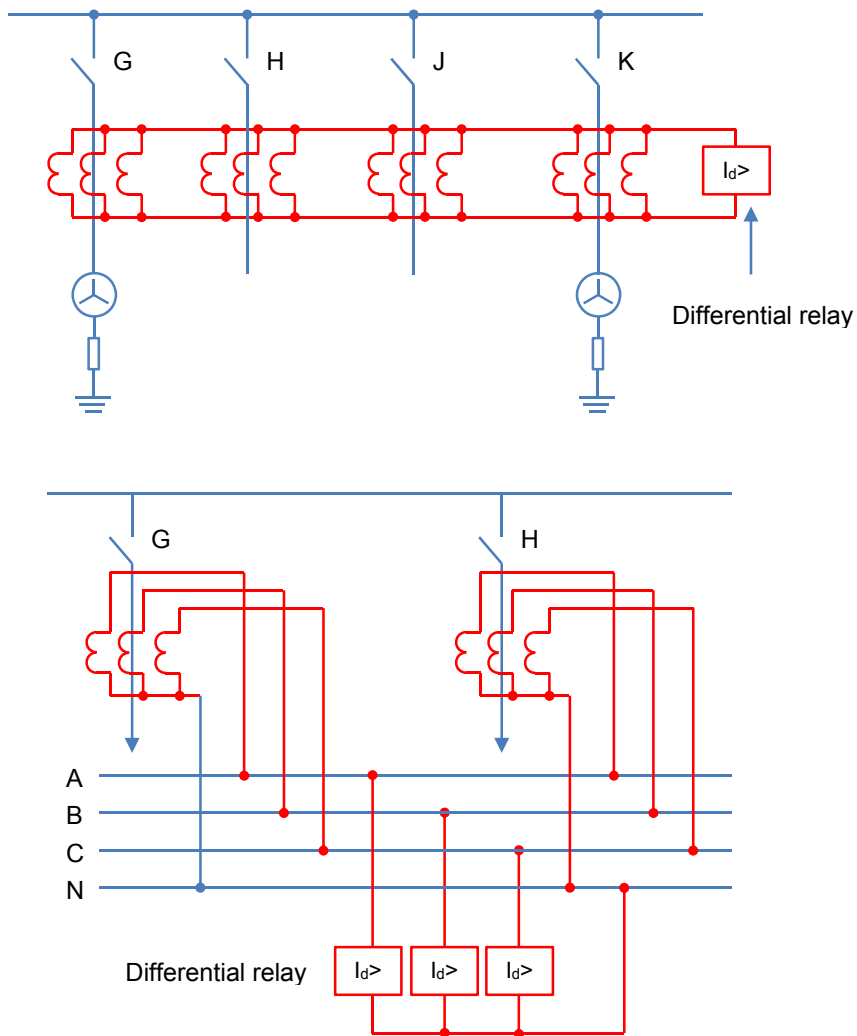

Figure 8. Circulating current configuration (a) Basic circulating current configuration (ground fault protection only) (b) Phase and ground fault circulating current configuration using three-element protection relay

The phase and ground fault settings are same, and this configuration is suggested for its ease of application and good operation.

DIFFERENTIAL PROTECTION FOR SECTIONALISED AND DUPLICATE BUSBARS

Each section of a divided bus is supplied with a separate circulating current system. The formed zones are overlapped across the section switches, so that a fault on the second will trip the two adjacent zones. This is presented in Figure 9. Tripping two zones for a section switch fault can be prevented by using the time-delayed method. Nevertheless, instantaneous tripping is the preferred option.

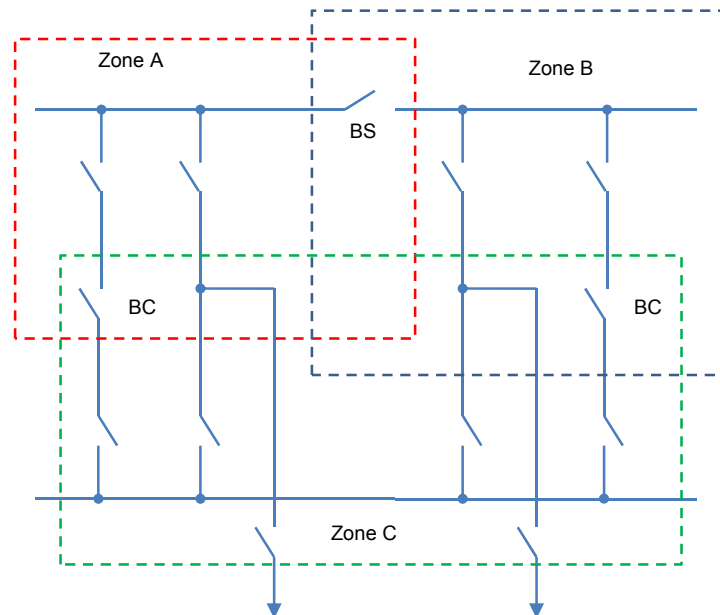

Figure 9. Protection zones for double bus station

For double bus configuration, the two busbars will be looked at as separate zones. The auxiliary busbar zone will overlap the corresponding main busbar zone at the bus coupler. Since any circuit may be transferred from one busbar to the other by isolator switches, these and the related tripping circuit must also be switched to the adequate zone by 'early make' and 'late break' auxiliary contacts. This is done to make sure that when the isolators are closing, the auxiliary switches make before the main isolator contacts, and that when the isolators are opened, and their main contacts part before the auxiliary switches open. The result is that the concerned two

zones secondary circuits are shortly paralleled while the circuit is being transferred. These two zones have in any case been grouped through the circuit isolators during the transfer operation.

CURRENT TRANSFORMERS LOCATION

In ideal case, the different discriminating zones should overlap each other as well as the individual circuit protections. The overlap should happen across a circuit breaker, so that the latter lies in both zones. For this configuration it is necessary to put current transformers on both sides of the circuit breakers, which is financially possible with many but not all switchgear types. With both the circuit and the bus protection current transformers on the same side of the circuit breakers, the protection zones may be overlapped at the current transformers, but a fault between the CT location and the circuit breaker will not be totally isolated. This issue is important in all switchgear to which these conditions are applicable, and is especially important in the case of outdoor switchgear where separately installed, multi-secondary current transformers are typically used. The conditions are presented in Figure 10.

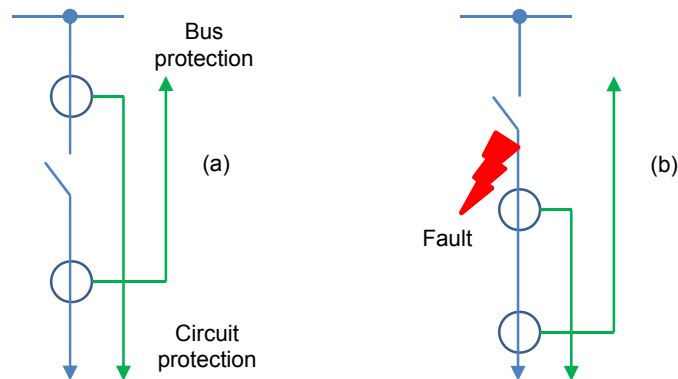

Figure 10. Unprotected zone with current transformers installed on only one side of the circuit breaker (a) Current transformers installed on both sides of breaker – no unprotected region (b) Current transformers installed only on circuit side of breaker – presented fault not cleared by circuit protection

Figure 10(a) presents the ideal configuration in which both the circuit and busbar zones are overlapped leaving no region of the primary circuit unprotected. Figure 10(b) presents how installation of all current transformers on the breaker circuit side ends in a small region of the primary circuit unprotected. This unprotected region is commonly referred to as the 'short zone'. Presented fault will cause operation of the busbar protection, tripping the circuit breaker, but the fault will continue to be supplied from the circuit, if a power source is present. It is mandatory for the bus protection to inter-trip the far end of the circuit protection, if the second is of the unit type. With reference to Figure 10(b), special 'short zone' protection can be installed to discover that the circuit breaker has opened but that the fault current is still running. Under these conditions, the protection can start an intertrip to the circuit remote end. This method may be used, especially when the circuit includes a generator. In this situation, the inter-trip shows that the fault is in the switchgear connections and not in the generator. Hence, the generator is tripped electrically but it is not mechanically shut down. Therefore, it is immediately ready for further service if the fault is cleared.

CT POSITIONS FOR MESH-CONNECTED SUBSTATIONS

The busbar protection in mesh connected substations introduces extra considerations in respect of CT location. A single mesh corner is presented in Figure 11(a). Where only one connection to the mesh is made at a corner, CTs installed as presented will give protection not only to the line but the corner of the mesh included between them. Nevertheless, this configuration cannot be used where more than one connection is made to a mesh corner. This is because a fault on any of the connected circuits would result in disconnection of them all, without any means of determining the faulted connection. Therefore, protection CTs must be installed on each connection, as presented in Figure 11(b). This leaves the mesh corner unprotected, so extra CTs and a protection relay to give mesh-corner protection are installed, as also presented in Figure 11(b).

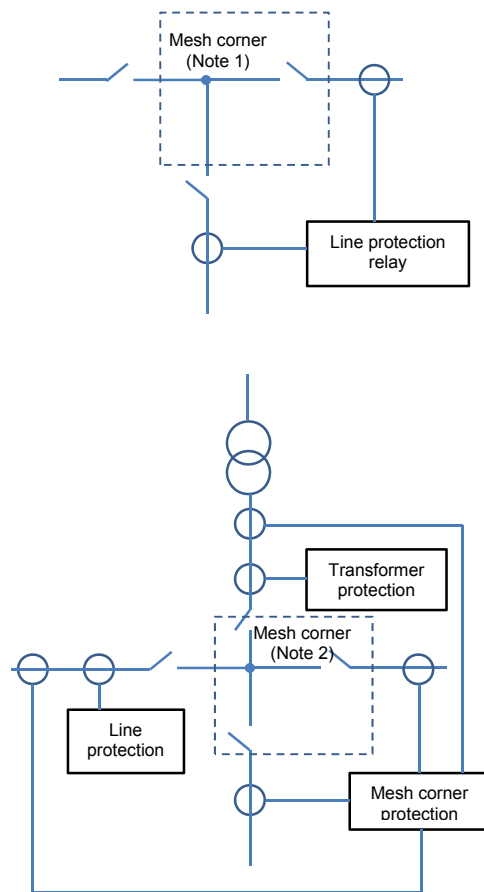

Figure 11. Mesh-corner protection (a) CT configuration for protection including mesh corner (b) CT configurations for protection – extra mesh corner protection needed

HIGH IMPEDANCE DIFFERENTIAL PROTECTION

This protection configuration is still in use. The issues that need to be considered are presented in the following sections.

STABILITY

The incidence of fault current with an initial unilateral transient component causes great flux build-up in a current transformer. When through fault current crosses differential system protected zone, the transient flux generated in the current transformers is not detrimental as long as it stays within the linear range of the magnetising curve. With fault current of considerable magnitude and long transient time constant, the flux density will go into the saturated region of the curve. This will

not generate a spill output from a pair of balancing current transformers given that these are same and equally burdened. A group of current transformers, even though they may be of the same design, will not be totally identical, but a more important factor is burden difference. In the case of a busbar differential system, an external fault may be supplied through a single circuit, the current being supplied to the busbar through all other circuits. The affected circuit is far more loaded than the others and the related current transformers are likely to be heavily saturated, while those of the other circuits are not. Therefore, serious unbalance is probable, which, with a protection relay of normal burden, could surpass any acceptable current setting. For this reason such systems were equipped with a time delay. However, this practice is no longer acceptable. It is not feasible to compute the spill current that may happen, but, fortunately, this is not required. An alternative approach gives both the necessary data and the technique needed to obtain a high performance. An equivalent circuit, shown in Figure 12, can represent a circulating current system.

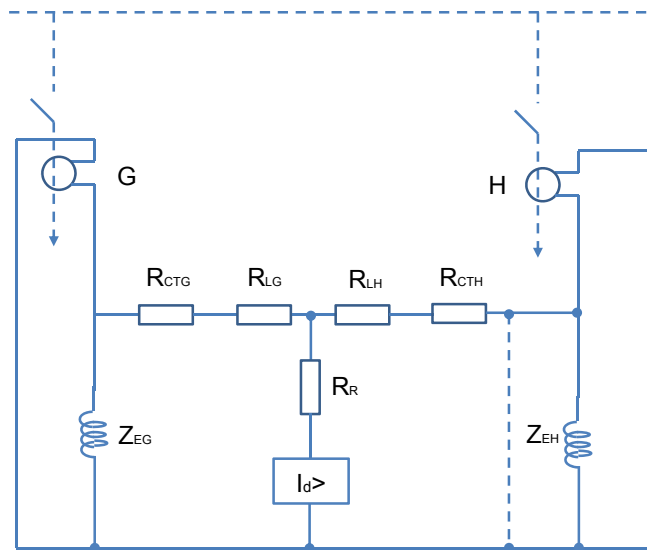

Figure 12. Circulating current system equivalent circuit

In the Figure 12, the current transformers are replaced by ideal current transformers feeding an equivalent circuit. It represents the magnetizing losses, secondary winding resistance, and also the resistance of the connecting leads. These circuits can then be interconnected as presented, with a protection relay connected to the junction points to form the complete equivalent circuit. Saturation has the effect of decreasing the exciting impedance, and is assumed to take place severely in current

transformer H until the shunt impedance becomes zero and the CT can generate no output. This condition is expressed by a short circuit, presented in broken line, across the exciting impedance. It should be clear that this is not the equivalent of a physical short circuit, since it is behind the winding resistance R_{CTH} . Using the Thévenin method of solution, the voltage developed across the protection relay will be expressed by:

$$V_f = I_f(R_{LH} + R_{CTH}) \quad (1)$$

The current through the protection relay is presented by:

$$I_R = \frac{V_f}{R_R + R_{LH} + R_{CTH}} = \frac{I_f(R_{LH} + R_{CTH})}{R_R + R_{LH} + R_{CTH}} \quad (2)$$

If R_R is small, I_R will come close to I_f , which is not allowed. On the other hand, if R_R is large I_R is decreased. Equation 2 can be presented, with little error, as follows:

$$I_R = \frac{V_f}{R_R} = \frac{I_f(R_{LH} + R_{CTH})}{R_R} \quad (3)$$

Or optionally,

$$I_R R_R = V_f = I_f(R_{LH} + R_{CTH}) \quad (4)$$

It is clear that, by increasing R_R , the spill current I_R can be decreased below any specified protection relay setting. R_R is usually increased by the installation of a series-connected resistor which is known as the stabilising resistor. It can also be noted from Equation 4 that it is only the voltage drop in the protection relay circuit at setting current that is important. The protection relay can be made as a voltage measuring element using negligible current; and provided its setting voltage surpasses the value V_f of Equation 4, the system will be stable. In fact, the setting voltage need not exceed V_f , since the derivation of Equation 4 involves an extreme condition of unbalance between the G and H current transformers that is not totally

realized. So a safety margin is built-in if the voltage setting is equal to V_f . It is important to note that the value of I_f to be inserted in Equation 4 is the total function of the fault current and the spill current I_R through the relay. If the case protection relay needs more time to function than the effective duration of the D.C. transient component, or has been made with special options to block the D.C. component, then this factor can be neglected and only the symmetrical value of the fault current need be used in Equation 4. If the protection relay setting voltage, V_S , is equal to V_f , that is, $I_f(R_L + R_{CT})$, an inherent safety factor of the order of two will be used.

In the case of a faster protection relay, capable of operating in one cycle and with no special options to block the D.C. component, the r.m.s. value of the first offset wave is significant. This figure, for a completely offset waveform with no d.c. decrement, is $\sqrt{3}I_f$. If settings are selected in terms of the symmetrical component of the fault current, the $\sqrt{3}$ factor which has been neglected will take up most of the basic safety factor, leaving only a insignificant margin.

Finally, if a completely instantaneous relay were used, the relevant value of I_f would be the maximum offset peak. In this situation, the factor has become less than unity, possibly as low as 0.7. Therefore, it is possible to rewrite Equation 4 as:

$$I_{SL} = \frac{K \times V_S}{R_L + R_{CT}} \quad (5)$$

Where

I_{SL} – stability limit of configuration

V_S – protection relay circuit voltage setting

$R_L + R_{CT}$ – lead + CT winding resistance

K – factor depending on protection relay design (range 0.7 – 2.0)

The current transformers will have an excitation characteristic which has not been associated to the protection relay setting voltage, the latter being equivalent to the maximum nominal voltage drop across the lead loop and the CT secondary winding resistance, with the maximum secondary fault current running through them. Under in-zone fault conditions it is mandatory for the current transformers to generate adequate output to operate the protection relay. This will be accomplished given the CT knee-point voltage surpasses the protection relay setting. In order to cater for errors, it is common to specify that the current transformers should have a knee-point e.m.f. of at least twice the necessary setting voltage. A greater multiple is useful to ensure a high speed of operation.

EFFECTIVE SETTING OR PRIMARY OPERATING CURRENT

The minimum primary operating current is an additional design criterion of a differential system. The secondary effective setting is the sum of the protection relay minimum operating current and the excitation losses in all parallel connected current transformers, whether carrying primary current or not. This summation should be vectorial, but is usually completed arithmetically. It can be presented as:

$$I_R = I_S + nI_{es} \quad (6)$$

Where

I_R – effective setting

I_S – protection relay circuit setting current

I_{es} – CT excitation current at protection relay voltage setting

n – number of parallel connected CTs

Having established the protection relay setting voltage from stability considerations, and knowing the current transformers excitation curve, the effective setting can be calculated. The secondary setting is converted to the primary operating current by

multiplying by the current transformers turns ratio. Determined operating current should be considered in terms of the application conditions. For a phase and ground fault arrangement the setting can be based on the expected fault current for minimum and maximum system outage conditions. Nevertheless, it should be kept in mind that:

- line-line faults give only 86% of the three-phase fault current
- fault arc resistance and ground path resistance decrease fault currents
- a reasonable margin should be provided to ensure that protection relays work quickly and decisively

It is preferable that the primary effective setting should not exceed 30% of the potential minimum fault current. In the case of a configuration exclusively for ground fault protection, the minimum ground fault current should be considered, taking into account any grounding impedance. Also, in the case of a double phase to ground fault, regardless of the inter-phase currents, only 50% of the system e.m.f. is available in the ground path, causing an additional decrease in the ground fault current. Therefore, the primary operating current must be not higher than 30% of the minimum single-phase ground fault current.

In order to accomplish high-speed operation, it is preferred that settings should be still lower, especially in the case of the solidly grounded power system. The transient component of the fault current in conjunction with unfavorable residual flux in the CT can generate a high degree of saturation and loss of output. This can potentially lead to a delay of several cycles that are additional to the natural operating time of the element. This will not happen to any high degree if the fault current is a higher multiple of setting. For instance, if the fault current is five times the configuration primary operating current and the CT knee-point e.m.f. is three times the relay setting voltage. The primary operating current is sometimes made to surpass the maximum anticipated circuit load in order to decrease the possibility of false operation under load current as a result of a broken CT lead. It will be seen that it is better not to increase the effective current setting too much, as this will reduce

speed. The check option in any case, keeps stability. An overall ground fault configuration for a large distribution board may be hard to accomplish because of the high number of current transformers paralleled together. This may lead to an excessive setting. It may be beneficial in such a case to provide a three-element phase and ground fault configuration, mainly to decrease the number of current transformers paralleled into one group.

Extra-high-voltage substations typically present no such problem. Using the voltage-calibrated protection relay, the current consumption can be insignificant. A simplification can be accomplished by providing one protection relay per circuit, all connected to the CT paralleling buswires. This allows the trip circuits to be limited to the least area and decreases the risk of accidental operation.

CHECK OPTION

Configurations for ground faults only can be checked by a frame-ground system, used for the switchboard as a whole. Subdivision is not necessary. For phase fault arrangements, the check will typically be a similar type of configuration that is used for the switchboard as a single overall zone. A set of current transformers separate from those applied in the discriminating zones should be given. No CT switching is needed and no current transformers are required for the check zone in bus-coupler and bus-section breakers.

CT SECONDARY CIRCUITS SUPERVISION

Any CT secondary circuit interruption up to the paralleling interconnections will create system unbalance that is equivalent to the load being carried by the relevant primary circuit. Although this degree of spurious output is below the effective setting the condition cannot be neglected, since it is likely to lead to instability under any through fault situation. Supervision can be accomplished to discover such conditions by connecting a sensitive alarm protection relay across the bus wires of each zone. For a phase and ground fault configuration, an internal three phase rectifier can be used to effect a summation of the bus wire voltages on to a single alarm element. The alarm protection relay is used so that operation does not happen with the healthy protection system under normal load. The alarm relay is made as sensitive

as possible. The desired effective setting is 125 primary amperes or 10% of the lowest circuit rating, whichever is the higher. Since a protection relay of this order of sensitivity is likely to function during through faults, a time delay, usually of three seconds, is used to avoid unnecessary alarm signals.

CT CONNECTION ARRANGEMENT

It is shown in Equation 4 how the voltage setting for a given stability level is directly related to the CT secondary leads resistance. Therefore, this should be kept to a practical minimum. Taking into consideration the practical physical laying of auxiliary cables, the CT bus wires are best arranged in the form of a ring around the switchgear site. In a double bus configuration, the CT leads should be taken directly to the isolator selection switches. The typical cable configuration on a double bus site is as follows:

- current transformers to marshalling kiosk
- marshalling kiosk to bus selection isolator auxiliary switches
- interconnections between marshalling kiosks to complete a closed ring

The protection relay for each zone is installed to one point of the ring bus wire. For cabling convenience, the main zone protection relays will be installed through a multicore cable between the protection relay panel and the bus section-switch marshalling cubicle. The reserve bar zone and the check zone protection relays will be connected together by a cable running to the bus coupler circuit breaker marshalling cubicle. It is possible that special cases involving onerous conditions may over-ride this convenience and make connection to some other part of the ring desirable. Connecting leads typically will not be less than 7/0.67mm (2.5mm²), but for big sites or in other difficult situations it may be necessary to use cables of, for example 7/1.04mm (6mm²) for the bus wire ring and the CT connections to it. The cable from the ring to the protection relay does not have to be of the larger section.

When the reserve bar is divided by bus section isolators and the two portions are protected as separate zones, it is mandatory to common the bus wires by means of auxiliary contacts. This makes these two zones into one when the section isolators are closed.

PRACTICAL DETAILS SUMMARY

This section gives a summary of practical considerations when using a high-impedance busbar protection configuration.

DESIGNED STABILITY LEVEL

For typical situations, the stability level should be made to correspond to the switchgear rating. Even if the system short-circuit power is less than this figure, it can be anticipated that the system will be developed up to the limit of rating.

CURRENT TRANSFORMERS

Current transformers must have identical turns ratios, but a turns error of one in 400 is accepted as a reasonable manufacturing tolerance. Also, current transformers should be of similar design. In the case this is not possible the magnetizing curves should be reasonably matched. Current transformers for application with high impedance protection configurations should meet the requirements of Class PX of IEC 60044-1.

SETTING VOLTAGE

The voltage setting is presented by the formula:

$$V_S \geq I_f(R_L + R_{CT})$$

Where:

I_f – steady state through fault current

V_S – protection relay circuit voltage setting

R_L – CT lead loop resistance

R_{CT} – CT secondary winding resistance

CURRENT TRANSFORMERS KNEE-POINT VOLTAGE

This is presented by the equation:

$$V_K \geq 2V_s$$

EFFECTIVE SETTING (SECONDARY)

The effective setting of the protection relay is presented by:

$$I_R = I_S + nI_{eS}$$

Where

I_S – protection relay circuit setting current

I_{eS} – CT excitation current at protection relay voltage setting

n – number of parallel installed CTs

For the primary fault setting multiply I_R by the CT turns ratio.

CURRENT TRANSFORMER SECONDARY RATING

It is clear from Equation 4 and Equation 6 that it is beneficial to maintain the secondary fault current low. This is accomplished by making the CT turns ratio high. It is typical procedure to use current transformers with a secondary rating of 1A. It can be demonstrated that there is an optimum turns ratio for the current transformers. This value depends on all application parameters but is typically around 2000/1. Even though a lower ratio, for instance 400/1, is sometimes used, the application of the optimum ratio can end in a considerable decrease in the physical size of the current transformers.

CURRENT TRANSFORMERS PEAK VOLTAGE

Under in-zone fault conditions, a high impedance protection relay makes an excessive burden to the current transformers, leading to the development of a high voltage. The voltage waveform will be greatly distorted but the peak value may be many times the nominal saturation voltage. When the burden resistance is finite, an estimate for the peak voltage is:

$$V_p = 2\sqrt{2}\sqrt{V_K(V_F - V_K)} \quad (7)$$

Where:

V_p – developed peak voltage

V_K – saturation voltage

V_F – prospective voltage in absence of saturation

This equation does not hold for the open circuit condition and is imprecise for very high burden resistances that approximate to an open circuit, because simplifying assumptions used in the formula derivation are not valid for the extreme situations. Another approach that can be applied to the open circuit secondary condition is:

$$V_p = \sqrt{2} \frac{I_f}{I_{ek}} V_K \quad (8)$$

Where:

I_f – fault current

I_{ek} – exciting current at knee-point voltage

V_K – knee-point voltage

Any burden connected across the secondary will decrease the voltage, but the value cannot be derived from a simple combination of burden and exciting impedances. Therefore, these equations should be considered only as a guide to the possible peak voltage. With large current transformers, especially those with a low secondary current rating, the voltage may be very high, above a suitable insulation voltage. The voltage can be fixed without detriment to the configuration by connecting a ceramic

non-linear resistor in parallel with the protection relay having a characteristic expressed by:

$$V = CI^\beta$$

where C is a constant depending on dimensions and β is a constant in the range 0.2 - 0.25.

The current transferred by the non-linear resistor at the protection relay voltage setting depends on the value of C; in order to maintain the shunting effect to a minimum it is suggested to use a nonlinear resistor with a value of C of 450 for relay voltages up to 175V and one with a value of C of 900 for setting voltages up to 325V.

HIGH IMPEDANCE PROTECTION RELAY

Instantaneous attracted armature relays or numeric relays that mimic the high impedance function are applied. Fast operating relays have a low safety factor constant in the stability Equation (5). The performance is enhanced by series-tuning the relay coil, therefore making the circuit resistive in effect. Inductive reactance would tend to decrease stability, whereas the capacitance action is to block the unidirectional fault current transient component and to increase the stability constant. An optional method applied to some protection relays is to use the limited spill voltage principle presented in Equation 4. A tuned element is connected via a plug bridge to a chain of resistors. The protection relay is calibrated in terms of voltage.

LOW IMPEDANCE BIASED DIFFERENTIAL PROTECTION

The majority of modern busbar protection configurations use principles of low impedance differential protection including the bias technique. The principles of a check zone, zone selection, and tripping configurations can still be used. Current transformer secondary circuits are not directly switched by isolator contacts but instead by isolator repeat relays after a secondary stage of current transformation. These switching relays make a replica of the busbar within the protection and provide the complete selection logic.

STABILITY

With some biased protection relays, the stability is not assured by the through current bias feature alone, but is improved by the addition of a stabilising resistor, that has a value which may be calculated as follows. The through current will increase the effective relay minimum operating current for a biased protection relay as follows:

$$I_R = I_S + BI_F$$

Where:

I_R – effective minimum operating current

I_S – relay setting current

I_F – through fault current

B – percentage restraint

Since I_F is typically much higher than I_S the relay effective current, $I_R = BI_F$.

From Equation (4) the value of stabilizing resistor is calculated using:

$$R_R = \frac{I_F(R_{LH} + R_{CTH})}{I_R} = \frac{(R_{LH} + R_{CTH})}{B}$$

It can be noted that the value of the stabilizing resistance is independent of current level, and that there seems to be no limit to the through fault stability level. This is known as 'The Principle of Infinite Stability'. The stabilising resistor still makes a major burden on the current transformers during internal faults. An optional technique is to block the differential measurement during the portion of the cycle that a current transformer is saturated. If this is accomplished by momentarily short-circuiting the differential path, a very low burden is put on the current transformers. In this way protection relay differential circuit is stopped from responding to the spill current. It must be realized that the use of any technique for inhibiting operation, to enhance stability performance for through faults, must not be allowed to diminish the ability of the protection relay to respond to internal faults.

EFFECTIVE SETTING OR PRIMARY OPERATING CURRENT

For an internal fault, and with no through fault current running, the effective setting I_R is increased above the basic relay setting I_S by whatever biasing effect is generated by the sum of the CT magnetizing currents running through the bias circuit. With low impedance biased differential configuration especially where the busbar installation has relatively few circuits, these magnetizing currents may be insignificant, depending on the value of I_S .

The basic relay setting current was expressed as the minimum current needed solely in the differential circuit to start operation – Figure 15(a). This method simplified performance assessment, but was considered to be unrealistic. In reality any current running in the differential circuit must run in at least one half of the relay bias circuit causing the practical minimum operating current always to be higher than the nominal basic setting current. As a result, a next definition, as presented in Figure 15(b) was developed. Conversely, it has to be appreciated that using the later definition of relay setting current, which runs through at least half the bias circuit, the notional minimum operation current in the differential circuit alone is lower, as presented in Figure 15(b). Using the definition presently applicable, the effective minimum primary operating current is

$$= N \left[I_S + B \sum I_{es} \right]$$

Where N=CT ratio

Unless the configuration minimum effective operating current has been deliberately increased to some preferred value, it will typically be set by the check zone. The latter may involve the highest number of current transformers in parallel. A somewhat more onerous condition may develop when two discriminating zones are coupled, transiently or otherwise, by the closing of primary isolators. Typically, it is desirable to achieve an effective primary operating current that is just higher than the maximum load current, to keep the busbar protection from operating spuriously from load current. This consideration is especially important where the check option is either not applied or is supplied from common main CTs.

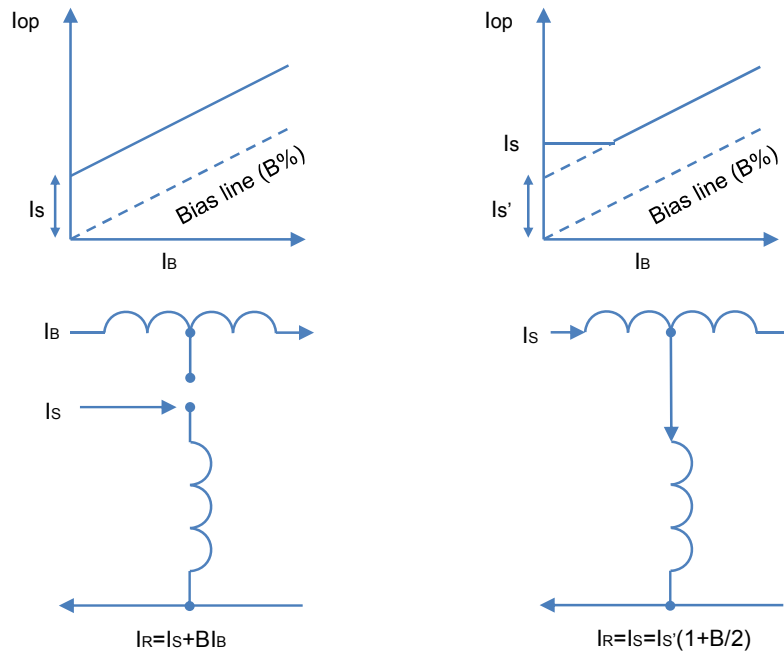

Figure 15. Definitions of relay setting current for biased protection relays (a) Replaced definition (b) Current definition

CHECK OPTION

For some low impedance configurations, only one set of main CTs is needed. This seems to conflict with the general principle of all busbar protection arrangements with a check feature, which requires duplication of all equipment. However, it is claimed that the spirit of the checking principle is accomplished by making protection operation dependent on two different criteria such as directional and differential measurements.

CT SECONDARY CIRCUITS SUPERVISION

In low impedance configurations the integrity of the CT secondary circuits can also be supervised. A current operated auxiliary relay, or the main protection equipment element, may be used to discover any unbalanced secondary currents and give an alarm after a time delay. For optimum discrimination, the current setting of this supervision relay must be less than that of the main differential protection. In modern busbar protection arrangements, the supervision of the secondary circuits commonly makes only a part of a comprehensive supervision facility.

CT CONNECTION ARRANGEMENT

It is a typical modern requirement of low impedance configurations that none of the main CT secondary circuits should be switched, to match the switching of primary circuit isolators. The common solution is to route all the CT secondary circuits back to the protection panel or cubicle to auxiliary CTs. It is then the secondary circuits of the auxiliary CTs that are switched as necessary. So auxiliary CTs may be used for this function even when the ratio matching is not in question. In static protection devices it is undesirable to use isolator auxiliary contacts directly for the switching without some form of insulation barrier. Position transducers that follow the opening and closing of the isolators may provide that. Optionally, a simpler configuration may be provided on multiple busbar arrangements where the isolators switch the auxiliary current transformer secondary circuits via auxiliary relays within the protection. These protection relays make a busbar replica and perform the necessary logic. Therefore, it is necessary to route all the current transformer secondary circuits to the protection relay to enable them to be connected into this busbar replica. Some configurations have only one set of current transformers available per circuit. Where the facility of a check zone is still needed, this can still be accomplished with the low impedance biased protection by installing the auxiliary current transformers at the input of the main and check zones in series, as presented in Figure 16.

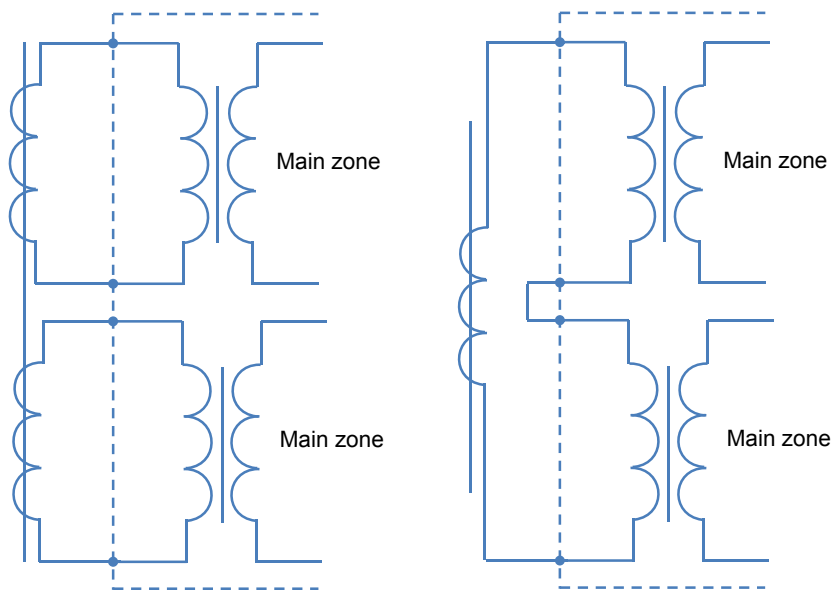

Figure 16. Optional CT connections

LOW IMPEDANCE BIASED DIFFERENTIAL PROTECTION - TYPE MBCZ

Numerical configurations are now dominant in the majority of new busbar protection installations. Nevertheless, in order to account for the previously installed equipment, and due to the similarity of the basic operating principles, this paragraph now considers a static configuration example – the MBCZ. The Type MBCZ configuration conforms to the principles presented earlier and contains a system of standard modules that can be set up to suit a specific busbar installation. Extra modules can be installed at any time as the busbar is extended.

A different module is used for each circuit breaker and also one for each protection zone. In addition to these there is a common alarm module and a number of power supply elements. Ratio correction facilities are supplied within each differential module to accommodate a wide range of CT mismatch. Figure 17 presents the correlation between the circuit breakers and the protection modules for a common double busbar installation.

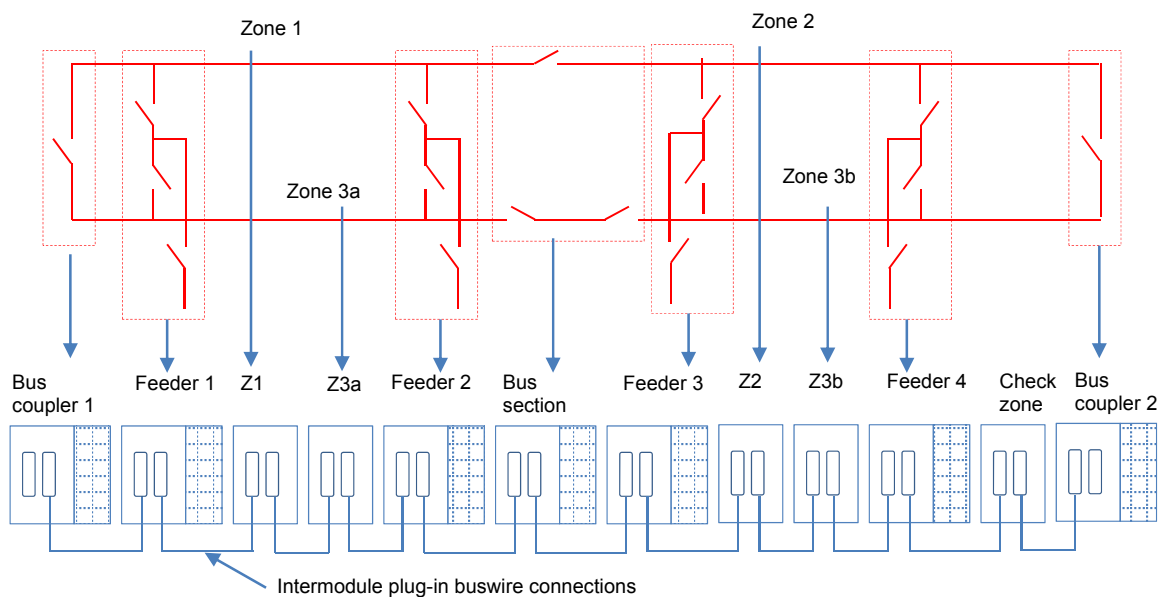

Figure 17. Type MBCZ busbar protection presenting correlation between circuit breakers and protection elements

The modules are connected via a multicore cable that is plugged into the back of the modules. There are five main groups of buswires, used for:

- main busbar protection
- reserve busbar protection
- transfer busbar protection. When the reserve busbar is also used as a transfer bus then this group of buswires is used
- auxiliary connections used by the protection to combine modules for some of the more complex busbar arrangements
- check zone protection

One extra module, not presented in this diagram, is plugged into the multicore bus. This is the alarm element, which contains the common alarm circuits and the bias resistors. The power supplies are also supplied through this module.

BIAS

All measurement zones are biased by the total current running to or from the busbar system via the feeders. This makes sure that all measurement zones will have similar fault sensitivity under all load conditions. The bias is gained from the check zone and fixed at 20% with a characteristic typically as presented in Figure 15(b). Hence, some ratio mismatch is tolerable.

STABILITY WITH SATURATED CURRENT TRANSFORMERS

The traditional method for stabilising a differential protection relay is to include a resistor to the differential path. While this enhances stability it increases the burden on the current transformer for internal faults. The technique applied to the MBCZ configurations solves this problem. The MBCZ technology discovers when a CT is saturated and short circuits the differential path for the portion of the cycle for which saturation happens. The resultant spill current does not then run through the measuring circuit and stability is accomplished. This principle allows a very low impedance differential circuit to be generated that will operate successfully with relatively small CTs.

OPERATION FOR INTERNAL FAULTS

If the CTs transferring fault current are not saturated there will be ample current in the differential circuit to trip the differential relay quickly for fault currents surpassing

the minimum operating level, which can be adjusted between 20% - 200% rated current. When the only CT(s) transferring internal fault current become saturated, it might be guessed that the CT saturation detectors may completely suppress operation by short-circuiting the differential circuit. Nevertheless, the resulting inhibit pulses remove only an insignificant part of the differential current, so protection relay operation is virtually unaffected.

DISCREPANCY ALARM FEATURE

Each measuring module comprises duplicated biased differential components and also a pair of supervision elements, which are a part of a complex supervision facility.

This configuration ensures supervision of CT secondary circuits for both open circuit conditions and any impairment of the element to operate for an internal fault, without waiting for an actual system fault condition. For a zone to trip it is mandatory for both the differential supervision element and the biased differential element to trip. For a circuit breaker to be tripped it needed the associated main zone to be tripped and also the overall check zone, as presented in Figure 19.

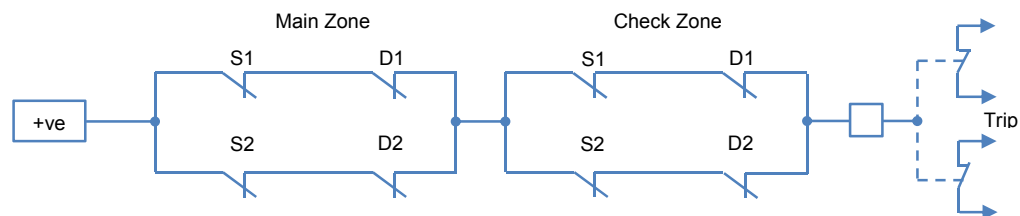

Figure 19. Busbar protection trip logic

MASTER/FOLLOWER MEASURING ELEMENTS

When two busbar sections are connected together by isolators it will result in two measuring elements being connected in parallel when the isolators are closed to operate the two busbar sections as a single bar. The fault current will then split between the two measuring elements in the ratio of their impedances. If both of the two measuring components are of low and equal impedance the effective minimum configuration operating current will be doubled. This is averted by using a 'master/follower' configuration. By making the impedance of one of the measuring

components much higher than the other it is feasible to ensure that one of the protection relays keeps its original minimum operation current. Then to ensure that both the parallel-connected zones are tripped the trip circuits of the two zones are connected in parallel. Any measuring element can have the role of 'master' or 'follower' as it is selectable by means of a switch on the front of the module.

TRANSFER TRIPPING FOR BREAKER FAULT

Serious damage may happen if a circuit breaker does not open when called upon to do so. To decrease this risk breaker fail protection configurations were developed. These configurations are typically based on the assumption that if current is still running through the circuit breaker a set time after the trip command has been sent then it has failed to function. The circuit breakers in the next stage are then automatically tripped. For a bus coupler or section breaker this involves tripping all the infeeds to the adjacent zone, a facility that is included in the busbar protection configuration.

NUMERICAL BUSBAR PROTECTION CONFIGURATIONS

The usage of numeric relay technology to busbar protection has become the preferred solution. The latest technology developments can be included, such as wide application of a data bus to link the different units, and fault tolerance against loss of a special link by providing multiple communications paths. The development process has been very strict, because the demands for busbar protection in respect of maloperation immunity are very high. A philosophy that can be used is distributed processing of the measured values, as presented in Figure 20. Feeders have their own processing unit, which gathers information on the state of the feeder (currents, voltages, CB and isolator status, etc.) and communicates it over high-speed fibre-optic links to a central processing unit. For large substations, more than one central processing unit may be installed, while in the case of small substations, all of the units can be co-located, leading to the appearance of a traditional centralized architecture.

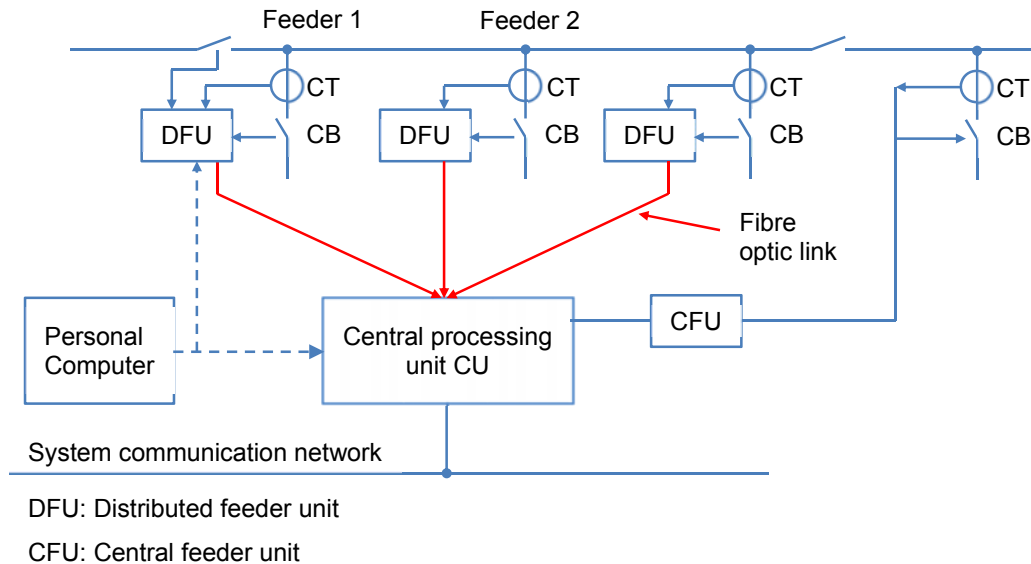

Figure 20. Architecture for numerical protection configuration

For simple feeders, interface units at a bay may be used with the data transferred to a single centrally installed feeder processing unit. The central processing unit completes required calculations for the protection functions. Provided protection functions are:

- backup overcurrent protection
- protection
- dead zone protection (alternatively referred to as 'short zone' protection)
- breaker failure

Also, monitoring functions such as CB and isolator monitoring, disturbance recording and transformer supervision are installed. Because of the applied distributed topology, synchronisation of the measurements done by the Feeder Units is of crucial importance. A high stability numerically-controlled oscillator is installed in each of the central and feeder units, with time synchronisation between them. In the case of loss of the synchronisation signal, the high stability of the oscillator in the affected feeder unit(s) allows processing of the incoming information to continue without major errors until synchronisation can be restored.

The feeder units have responsibility for gathering the needed information, such as voltages and currents, and processing it into digital form for onwards transmission to

the central processing unit. CT response modeling is included, to avoid errors caused by effects such as CT saturation. Disturbance recording for the monitored feeder is used. Because each feeder unit is concerned only with an individual feeder, the differential protection algorithms must be kept in the central processing unit. The differential protection algorithm can be much more sophisticated than with previous technology, due to processing power improvements. In addition to computing the sum of the measured currents, the algorithm can also assess differences between successive current samples, since a large variation above a threshold may show a fault. The same considerations can also be used to the current phase angles, and incremental changes in them. One benefit gained from the application of numerical technology is the ability to easily re-configure the protection to cater for substation configuration changes. For example, installation of an extra feeder involves the addition of an extra feeder unit, the fiber-optic connection to the central unit and entry via the HMI of the new configuration into the central processor unit. Figure 21 presents the latest numerical technology.



Figure 21. Busbar protection relay using the latest numerical technology

RELIABILITY CONSIDERATIONS

When considering the introduction of numerical busbar protection systems, users have been concerned with reliability issues such as security and availability. Typical high impedance configurations have been one of the main protection arrangements used for busbar protection. The basic measuring element is simple in concept and has few elements. Stability limit calculations and setting other parameters is straightforward and arrangement performance can be predicted without the need for costly testing. High impedance arrangements have proved to be a very reliable protection form. In contrast, modern numerical arrangements are more complex with a higher range of facilities and a higher component count. Based on low impedance bias methods, and with a bigger range of facilities to set, setting calculations can also be more complex. Nevertheless, studies of the comparative reliability of conventional high impedance arrangements and modern numerical configurations have shown that evaluating relative reliability is not simple as it might seem. The numerical arrangement has two benefits over its older counterpart:

- There is a decrease in the number of external components such as switching and other auxiliary relays. Many of these functions are internally completed within the software algorithms

- Numerical arrangements include complex monitoring features which give alarm facilities if the arrangement is faulty. In certain situations, simulation of the arrangement functions can be completed on line from the CT inputs through to the tripping outputs. Therefore arrangement functions can be checked on a regular basis to make sure a full operational mode is available at all times Reliability assessment using fault tree analysis methods have examined issues of dependability (i.e. the ability to trip when needed) and security (i.e. the ability not to provide spurious/indiscriminate operation). These assessments have shown that:
 - Dependability of numerical arrangements is better than typical high impedance configurations

- Security of numerical and conventional high impedance arrangements are comparable

Also, an important option of numerical configurations is the in-built monitoring system. This considerably enhances the potential availability of numerical configurations in comparison to conventional arrangements since faults within the equipment and its operational state can be discovered and alarmed. With the conventional arrangement, failure to correctly re-instate the configuration after maintenance may not be detected until the configuration is required to operate. In this case, its effective availability is zero until it is discovered and repaired.

INTERLOCKED OVERCURRENT BUSBAR ARRANGEMENTS

Dedicated busbar protection, such as high impedance or biased differential, is commonplace for transmission and sub-transmission systems. This provides fast fault clearance, operating subcycle in some situations. The situation is a little different for distribution substations, where utilities consider the large number of stations, the large number of feeder circuits, and may wish to consider an economical alternative solution.

Interlocked overcurrent configurations, also known as 'busbar blocking' or 'zone sequence interlocking' configurations can provide that economical alternative. The benefit is that the busbar protection needs no dedicated relay(s), as it is configured to trip using logic facilities already available in the feeder manager overcurrent relays. They are installed on the incoming and outgoing feeders. Since feeder protection must be provided for all circuits emanating from the busbar, the only extra cost to configure the busbar protection is to design and install the means for the separate relays to communicate peer-to-peer with each other. Figure 22 presents a simple single incomer substation on a radial system, with four outgoing lines. It can be shown that for any downstream fault, whether external to the substation, or in-zone on the busbar, the incoming feeder relay will discover the flow of fault current. The fault current level can be similar, therefore on the basis of overcurrent or ground fault detection alone, the incoming feeder relay cannot discriminate whether the fault

is in-zone and demands a trip or whether it is external (and tripping only by the correct outgoing feeder relay is needed).

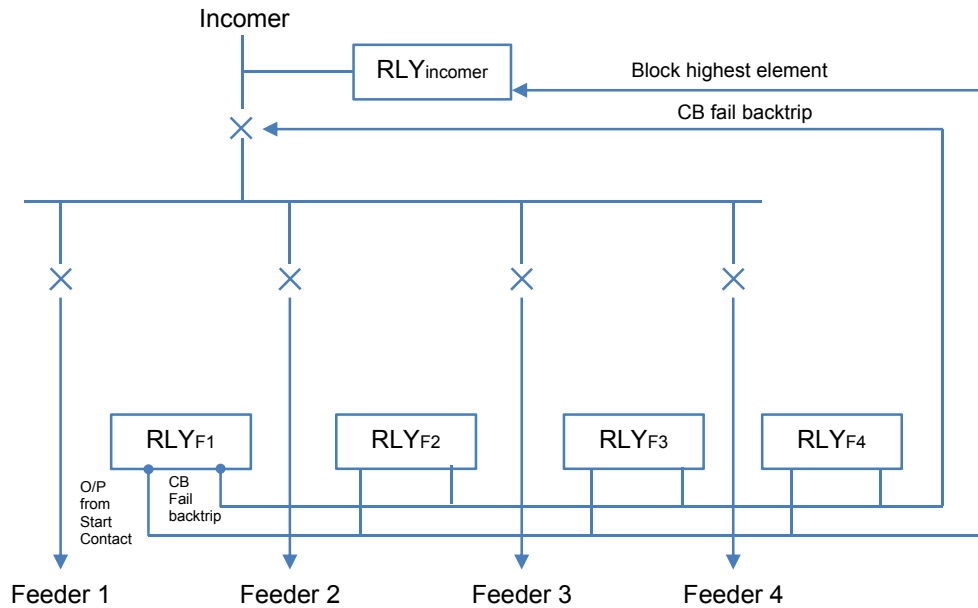

Figure 22. Simple busbar blocking configuration (single incomer)

Nevertheless, most numerical feeder protection relays have the means to send an instantaneous start output, to indicate that they are measuring an operating current above setting. Figure 22 presents how this facility can be used in the outgoing feeder protection relays, and communicated to the incomer relay as a 'block' signal. This block does not block the vital time-overcurrent function in the incomer protection relay, but merely blocks a definite-time high-set that has been particularly configured to offer busbar protection. The high-set, phase overcurrent measurement is delayed by a margin marked as 'time to block' as presented in Figure 23. This deliberate operation delay is necessary to allow sufficient time for an external fault to be discovered by an outgoing feeder protection relay. It also gives enough time for it to be communicated as a 'block' command, and acted upon by the incomer relay. Only if the incoming feeder protection relay measures fault current above the high-set setting, and no block arrives, it determines that the fault must lie on the protected busbar, and a bus zone trip command is created.

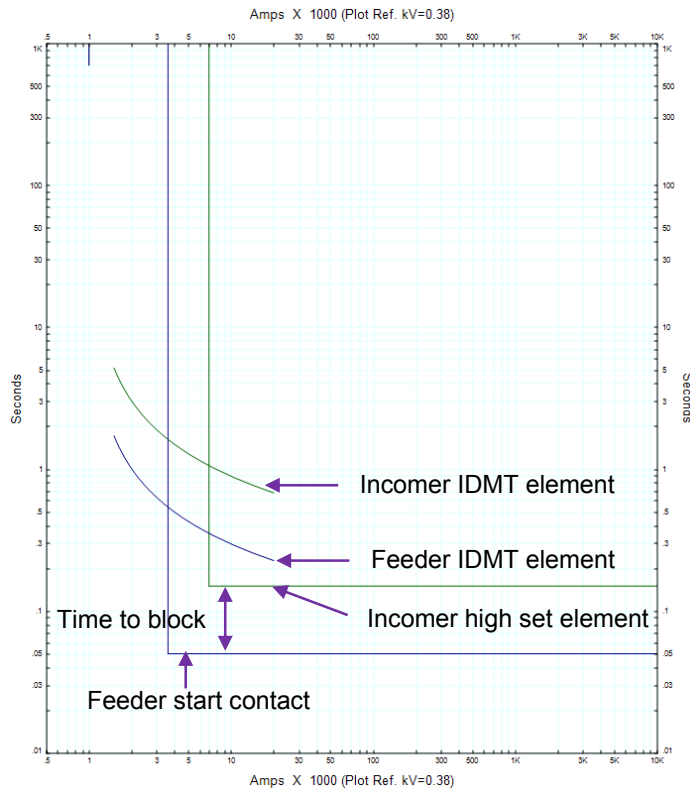

Figure 23. High-set bus-zone tripping: element coordination

The definite time delay - 'time to block' - will typically be of the order of 50 to 100ms, meaning that the operating time for a genuine busbar fault will be of the order of 100ms. This delayed clearance may not be a problem, as system stability is commonly not a primary concern for distribution systems. Indeed, 100ms operation would be much faster than waiting for the incoming feeder I.D.M.T. curve to time out. Figure 22 presented that block signals would be exchanged between protection relays by hardwiring, and this is still a valid solution for simplicity. Modern implementation would be to use IEC 61850 GOOSE logic to exchange such commands via Ethernet. Whether made as hardwired, or Ethernet schemes, circuit breaker failure is also typically used. Interlocked overcurrent busbar configurations may also be used to sectionalized busbars, with more than one incomer, given that directional protection relays are used on any feeder which may act as an infeed, and at each bus section. Nevertheless, such configurations are unlikely to be applicable in double busbar stations, where dedicated busbar protection is suggested.